

VDR13 Design Series Variable Volume Vane Pump

20 to 45ℓ/min
6MPa

❖ The new design number 13 was created by modifying some of the components of old design numbers 11 and 12, and the new design installation compatible with the old design.

Features

- ① Energy efficient, economical operation.
- ② Built-in high-precision temperature compensation mechanism.
- ③ The ring is displaced by a spring, and a rise in pressure automatically moves it to the center to make the discharge rate zero.
- ④ Relief valve and unloading valve can be eliminated from the circuit.
- ⑤ It was possible to reduce the size of the unit because there was no increase of proportional input to pressure which prevented increases in the temperature of the fluid.
- ⑥ New design for lower noise and improved durability.

Specifications

Single Pump

Model No.	Capacity cm ³ /rev	No-load Discharge Rate (ℓ/min)				Pressure Adjustment Range MPa{kgf/cm ² }	Allowable Peak Pressure MPa {kgf/cm ² }	Revolution Speed min ⁻¹		Weight kg
		1000min ⁻¹	1200min ⁻¹	1500min ⁻¹	1800min ⁻¹			Min.	Max.	
VDR-1A(B)-1A1-13	13.9	14	16.5	21	25	1 to 2 {10.2 to 20.6}	14 {143}	800	1800	8
-1A2-	13.9	14	16.5	21	25	1.5 to 3.5 {15.3 to 35.7}				
-1A3-	11.1	11	13	17	20	3 to 6 {30.6 to 61.2}				
VDR-2A(B)-1A1-13	25	25	30	38	45	1 to 2 {10.2 to 20.4}	14 {143}	800	1800	21
-1A2-	25	25	30	38	45	1.5 to 3.5 {15.3 to 35.7}				
-1A3-	22.2	22	26.5	34	40	3 to 6 {30.6 to 61.2}				

Double Pump

Model No.	Vent Side		Shaft Side		Vent Side	Shaft Side	Revolution Speed min ⁻¹		Weight kg
	Discharge Rate ℓ/min	Pressure Adjustment Range MPa{kgf/cm ² }	Discharge Rate ℓ/min	Pressure Adjustment Range MPa{kgf/cm ² }	Allowable Peak Pressure MPa{kgf/cm ² }		Min.	Max.	
VDR-11A(B)-1A1-1A1-13 VDR-11A(B)-1A1-1A2-13 VDR-11A(B)-1A1-1A3-13	25	1 to 2 {10.2 to 20.4}	25	1 to 2 {10.2 to 20.4} 1.5 to 3.5 {15.3 to 35.7}	14 {143}	800	1800	A : 13.6 B : 13.9	
VDR-11A(B)-1A2-1A2-13 VDR-11A(B)-1A2-1A3-13		1.5 to 3.5 {15.3 to 35.7}	25	1.5 to 3.5 {15.3 to 35.7} 3 to 5 {30.6 to 51}					14 {143}
VDR-11A(B)-1A3-1A3-13	20	3 to 5 {30.6 to 51}	20	3 to 5 {30.6 to 51}	14 {143}				

Note) 1. The discharge rate is the value at 1800min⁻¹ no-load.

2. In addition to this model, the VDC Series (maximum working pressure: 14MPa) high-pressure variable vane pump is also available. See page B-25 for more information.
3. The change from VDR-1 Series design number 11 to design number 12 represents a change in the shaft key width from 3.2mm to 4.76mm. This means that when using a 3.2mm key coupling, you need to use a stepped key (VD31J-302000) or add a new key groove at 4.76.
4. There is no change in the mounting method with the change from the VDR-1 size design number 12 and VDR-2 design number 11 to design number 13.

Explanation of model No.

Single Pump

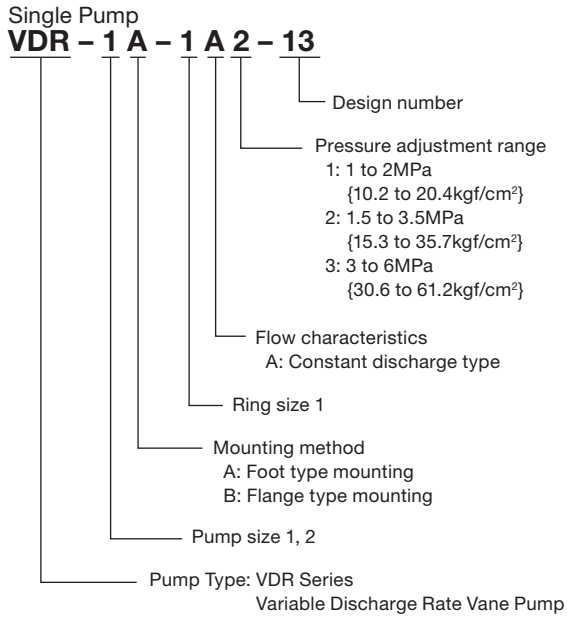

Double Pump

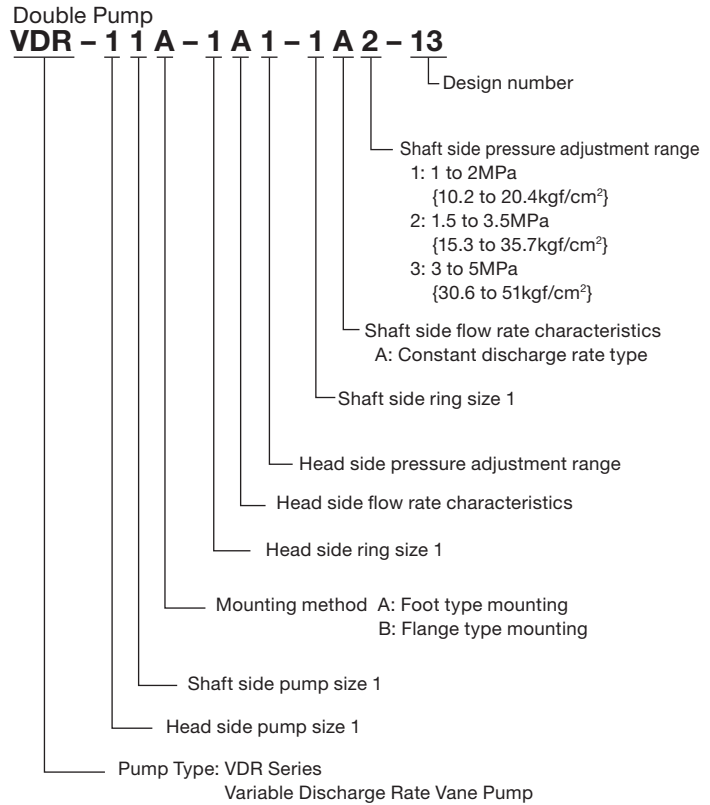

● Handling

1 Rotation Direction

The direction of rotation is always clockwise (rightward) when viewed from the shaft side.

2 Drain

Drain piping must be direct piping up to a point that is below the tank fluid level, and back pressure due to pipe resistance should not exceed 0.03MPa.

3 Discharge Volume Adjustment

The discharge flow rate is decreased by clockwise (rightward) rotation of the discharge rate adjusting screw, and increased by counterclockwise (leftward) rotation. Loosen the lock nut before making adjustments. After adjustment is complete, re-tighten the lock nut. The graph below provides general guidelines for the relationship between the rotation angle of the flow rate adjusting screw and the no-load discharge rate.

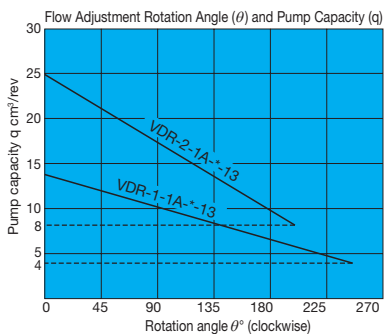

However:

Q : No-load Discharge Rate Q_L /min
 q : Volume cm^3/rev
 N : Revolution Speed min^{-1}

4 Pressure Adjustment

Pressure is decreased by clockwise (rightward) rotation of the discharge rate adjusting screw, and increased by counterclockwise (leftward) rotation.

5 Factory Default P-Q Settings (Standard Model)

- Flow Rate Setting = Maximum flow rate for model as indicated in the catalog
- Pressure Setting = Pressure shown in table to the right

6 Initial Operation

Before operating the pump for the first time, put the pump discharge side into the no-load state and then repeatedly start and stop the motor to bleed all air from inside the pump and the suction piping. After confirming that the pump is discharging oil, continue the no-load operation for at least 10 minutes to discharge all the air from the circuit.

Note) The values indicated above are at maximum pump discharge volume with the flow volume adjusting screw at the 0° position. The broken line shows the flow volume adjustment range lower limit value.

Factory Default Pressure Settings

Pressure Setting	MPa	{kgf/cm ² }
1 : 2		{20.4}
2 : 3.5		{35.7}
3 : 3		{30.6}

(Provide an air bleed valve in circuits where it is difficult to bleed air before startup.)

7 Sub Plate

When a sub plate is required, specify a sub-plate type from the table in the installation dimension diagram.

8) For the hydraulic operating fluid, use an R&O type and wear-resistant type of ISO VG32 to 68 or equivalent (viscosity index of at least 90). Use hydraulic operating fluid that provides kinematic viscosity during operation in the range of 20 to 150mm²/s.

9) The operating temperature range is 15 to 60°C. When the oil temperature at startup is 15°C or less, perform a warm-up operation at low pressure and low speed until the oil temperature reaches 15°C. Use the pump in an area where the temperature is within the range of 0 to 60°C.

10) Suction pressure is -0.03 to +0.03MPa (-0.3 to +0.3kgf/cm²), and the suction port flow rate should be to greater than 2m/sec.

- 11 Avoid pulley, gear, and other drive systems that impart a radial or thrust load on the end of the pump shaft. Mount the pump so its pump shaft is oriented horizontally.
- 12 Provide a suction strainer with a filtering grade of about $100\mu\text{m}$ (150 mesh). For the return line to the tank, use a $25\mu\text{m}$ line filter.
- 13 Manage hydraulic operating fluid so contamination is maintained at ISO4406 21/19/16 or lower. Take care to avoid contamination with water and other foreign matter, and watch out for discoloration. Whitish fluid indicates that air has contaminated the fluid, and brownish fluid indicates the fluid is dirty.

- 14 At startup, repeat the inching operation (start-stop) to bleed air from the pump and pipes.
- 15 Equip an air bleed valve in circuits where it is difficult to bleed air before startup. See page C-13 for more information.
- 16 To ensure proper lubrication of the pump's rubbing surfaces, supply oil to the interior of the pump before starting operation.
- 17 When centering the pump shaft, eccentricity with the motor shaft should be no greater than 0.05mm. Use a pump mounting base of sufficient rigidity. The angle error should be no greater than 1° .

● Inverter Drive Precautions

- 1 Set the revolution speed within the range of the pump specification revolution speed.
- 2 Changing the revolution speed may also affect the pump performance curves. Before using the inverter, check if the pressure and motor load factor are within the range of use.

Installation Dimension Drawings

VDR-1A-*-13 (Foot Mounting)

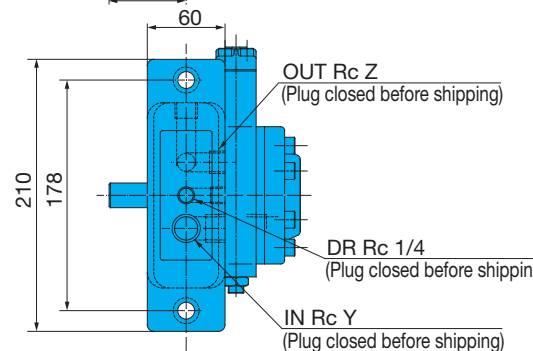
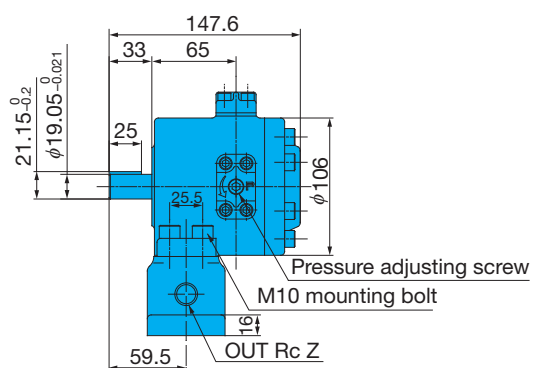
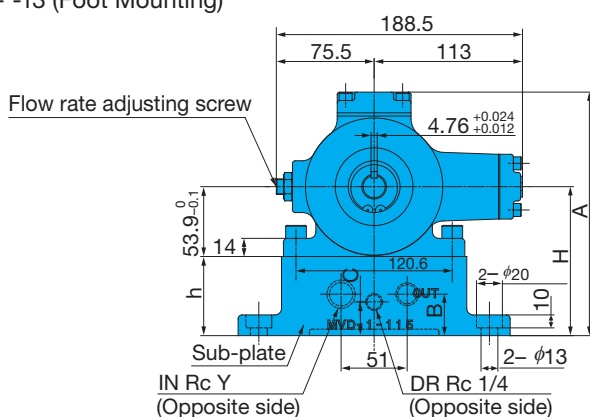

Note: Sub-plate is not provided. Must be provided separately if needed.

Sub Plate Number	Weight kg	H	h	A	B	C	Y	Z	Motor Output kW(4P)
MVD-1-115-10	3.7	115	61.1	188	32	26	1/2	3/8	0.75 to 1.5
MVD-1-115Y-10							3/4	1/2	
MVD-1-135-10	4.9	135	81.1	208	40	40	1/2	3/8	2.2 to 3.7
MVD-1-135Y-10							3/4	1/2	

VDR-1B-*-13 (Flange Mounting)

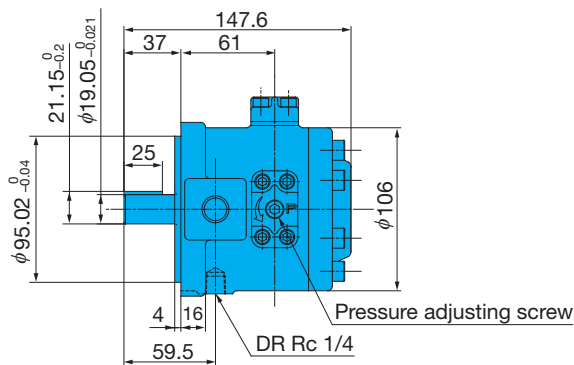
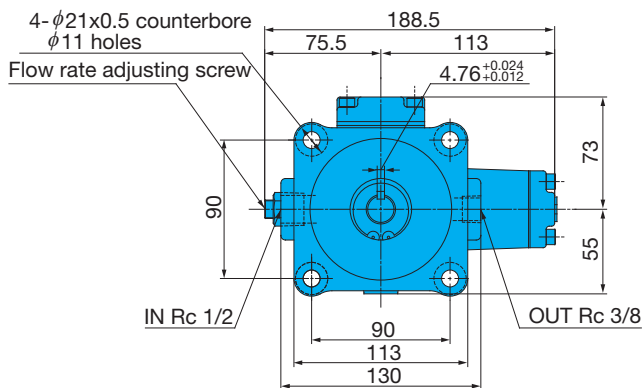

VDR-2A-*-13 (Foot Mounting)

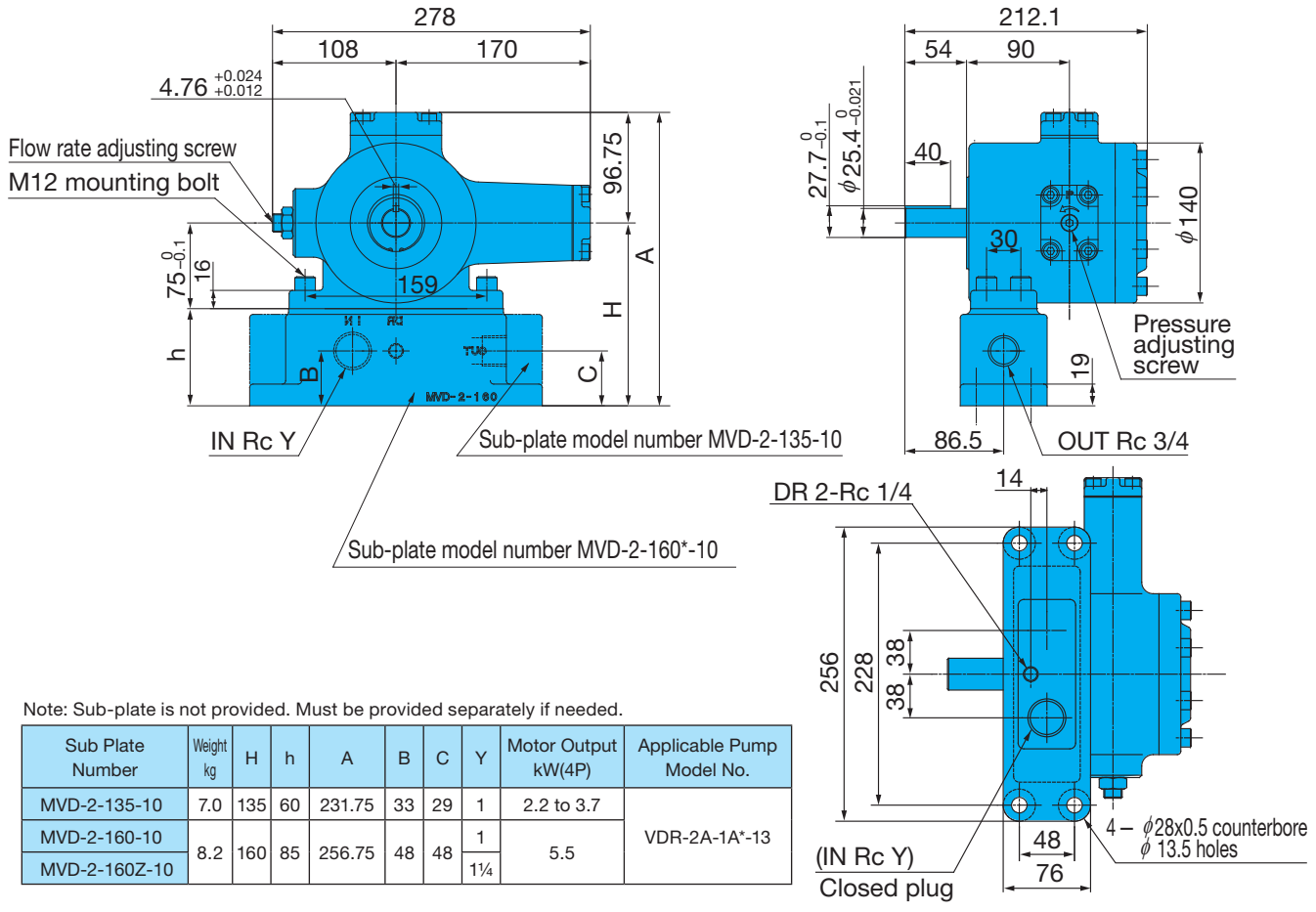

Note: Sub-plate is not provided. Must be provided separately if needed.

Sub Plate Number	Weight kg	H	h	A	B	C	Y	Motor Output kW(4P)	Applicable Pump Model No.
MVD-2-135-10	7.0	135	60	231.75	33	29	1	2.2 to 3.7	VDR-2A-1A*-13
MVD-2-160-10	8.2	160	85	256.75	48	48	1	5.5	
MVD-2-160Z-10							1/4		

VDR-2B-*-13 (Flange Mounting)

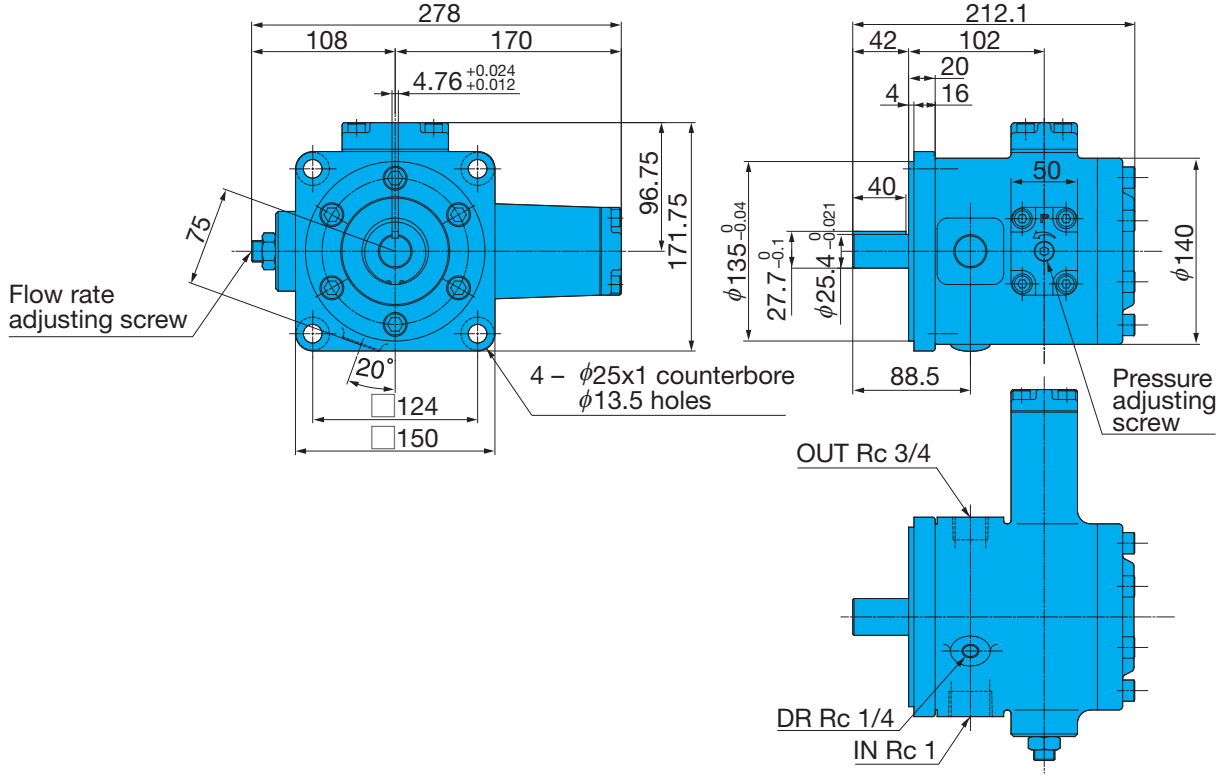

Performance Curves

Typical characteristics at hydraulic operating fluid kinematic viscosity of 32 mm²/s

Revolution Speed 1500min⁻¹ —●—
1800min⁻¹ —□—

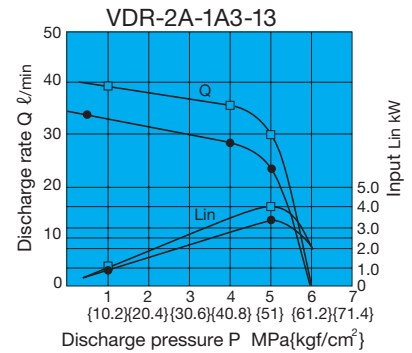
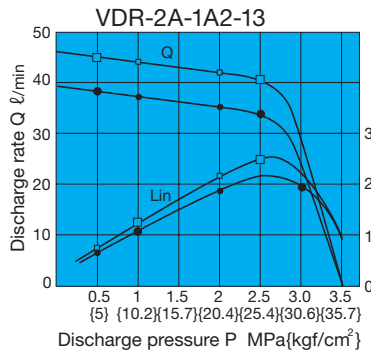
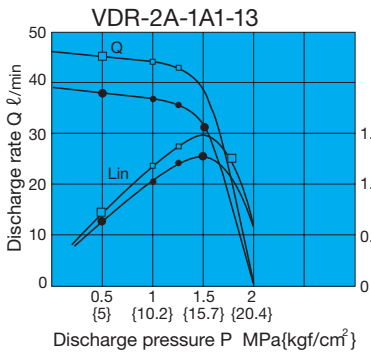
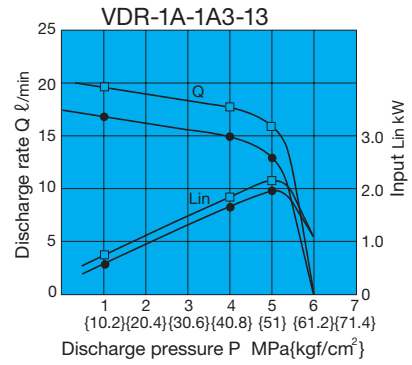
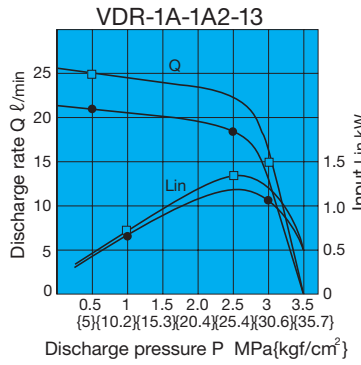
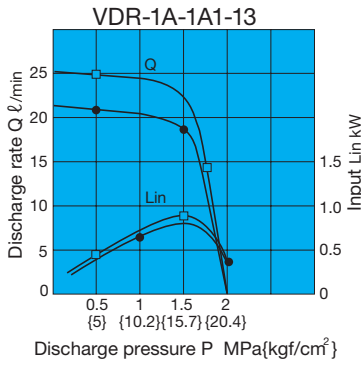

Axial Input At Full Cutoff

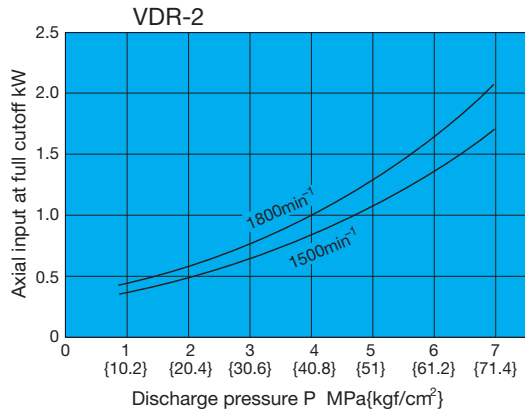
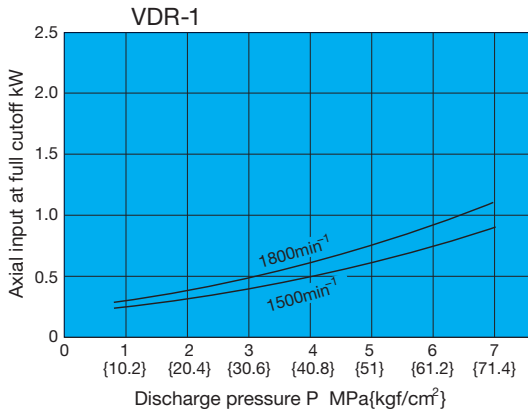

Noise Characteristics

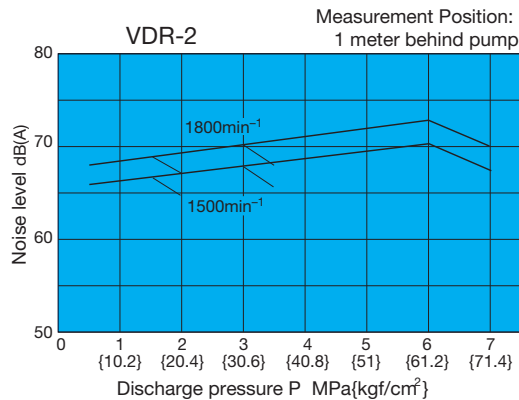
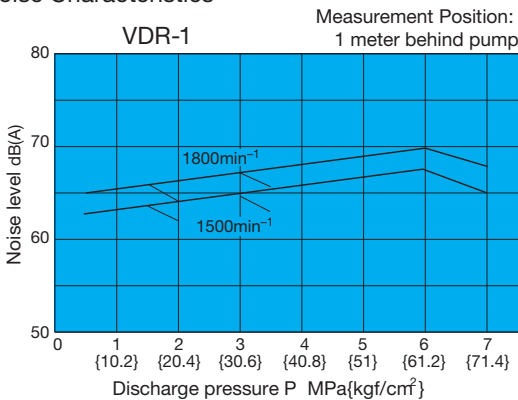

Cross-sectional Drawings

VDR-1A-*-13
VDR-2A-*-13

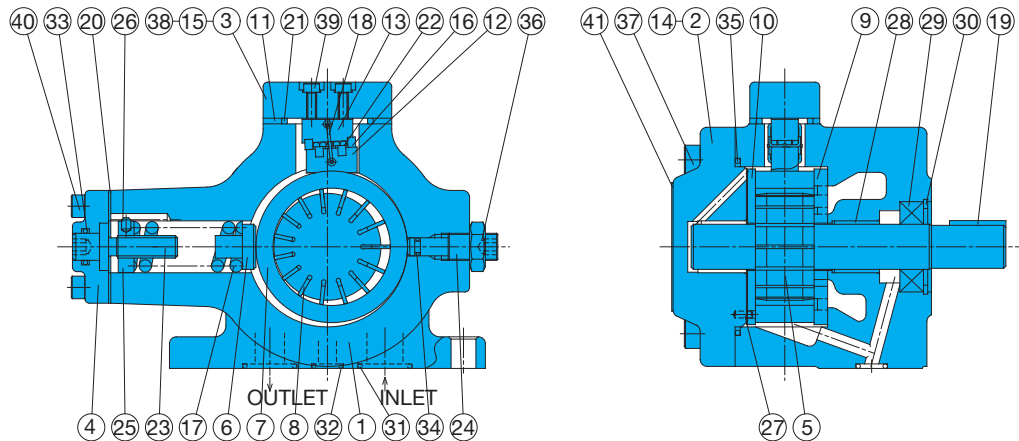

List of Sealing Parts

Part No.	Applicable Pump Model No.	VDR-1A-*-13		VDR-2A-*-13	
	Seal Kit Number	VDAS-101A00		VDAS-102A00	
	Part Name	Part Number	Q'ty	Part Number	Q'ty
20	Packing	VD32J-101000	1	VD32J-102000	1
21	Square ring	VD33J-101000	1	NBR-70-1 G45	1
29	Oil seal	ISRD-204010	1	TCV-284811F	1
31	O-ring	NBR-70-1 P20	2	NBR-70-1 G30	2
32	O-ring	NBR-70-1 P10A	1	NBR-70-1 P12	1
33	O-ring	NBR-70-1 P12	1	NBR-70-1 P14	1
34	O-ring	NBR-70-1 P5	1	NBR-70-1 P9	1
35	O-ring	NBR-70-1 G70	1	NBR-70-1 G100	1

Part No.	Part Name	Part No.	Part Name	Part No.	Part Name
1	Body	15	Shim	29	Oil seal
2	Cover	16	Retainer	30	Snap ring
3	Cover	17	Spring	31	O-ring
4	Cover	18	Spring	32	O-ring
5	Shaft	19	Key	33	O-ring
6	Piston	20	Packing	34	O-ring
7	Ring	21	Square ring (O-ring)	35	O-ring
8	Vane	22	Needle	36	Nut
9	Plate (S)	23	Screw	37	Screw
10	Plate (H)	24	Screw	38	Screw
11	Plate	25	Nut	39	Screw
12	Holder	26	Pin	40	Screw
13	Holder	27	Pin	41	Nameplate
14	Shim	28	Bearing		

Note) 1. Oil seals are manufactured by Nippon Oil Seal Industry Co.Ltd. (NOK).

2. The materials and hardness of the O-ring conform with JIS B2401.

3. For VDR-*B-*-13, the seal kit number becomes VDBS-10*B00, without the 31 and 32 O-rings.

VDR-11A-*-13

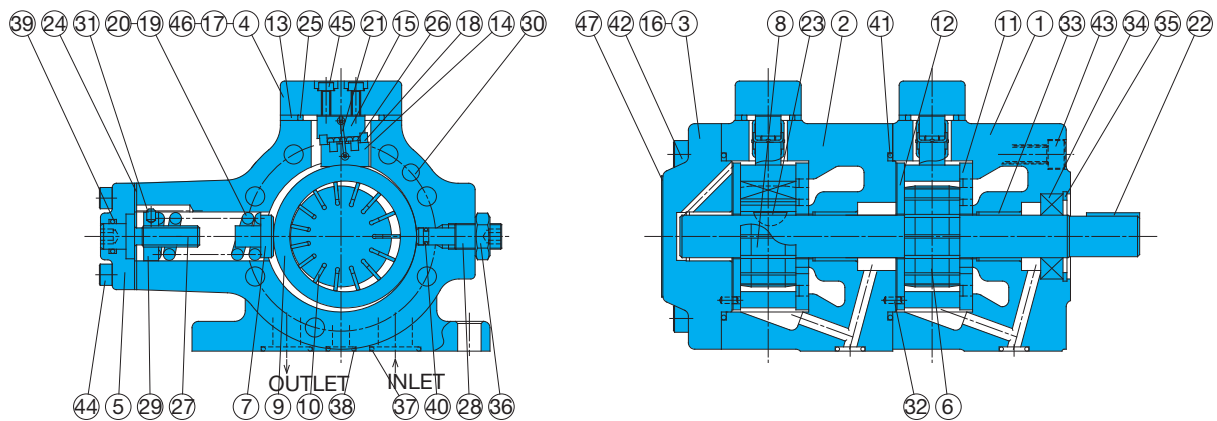

List of Sealing Parts

Part No.	Applicable Pump Model No.	VDR-11A-*-13	
	Seal Kit Number	VDAS-111A00	
	Part Name	Part Number	Q'ty
24	Packing	VD32J-101000	2
25	Square ring	VD33J-101000	2
34	Oil seal	ISRD-204010	1
37	O-ring	NBR-70-1 P20	4
38	O-ring	NBR-70-1 P10A	2
39	O-ring	NBR-70-1 P12	2
40	O-ring	NBR-70-1 P5	2
41	O-ring	NBR-70-1 G70	2

Part No.	Part Name	Part No.	Part Name	Part No.	Part Name
1	Body	11	Plate (S)	21	Spring
2	Body	12	Plate (H)	22	Key
3	Cover	13	Plate	23	Key
4	Cover	14	Holder	24	Packing
5	Cover	15	Holder	25	Square ring
6	Shaft	16	Shim	26	Needle
7	Piston	17	Shim	27	Screw
8	Rotor	18	Retainer	28	Screw
9	Ring	19	Spring	29	Nut
10	Vane	20	Spring	30	Pin

Part No.	Part Name
31	Pin
32	Pin
33	Bearing
34	Oil seal
35	Snap ring
36	Nut
37	O-ring
38	O-ring
39	O-ring
40	O-ring
41	O-ring
42	Screw
43	Screw
44	Screw
45	Screw
46	Screw
47	Nameplate

Note) 1. Oil seals are manufactured by Nippon Oil Seal Industry Co. Ltd. (NOK).

2. The materials and hardness of the O-ring conform with JIS B2401.

3. For VDR-11B-*-13, the seal kit number becomes VDAS-111B00, without the 37 and 38 O-rings.